



DOWNLOAD



DOWNLOAD

[Fet High Side Driver For Mac](#)

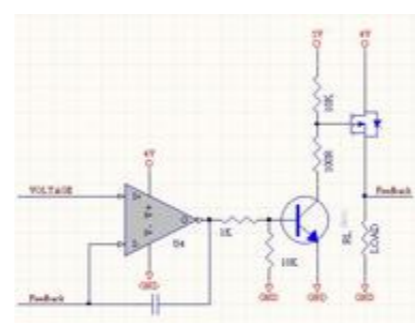

[Fet High Side Driver For Mac](#)



DOWNLOAD



DOWNLOAD

These are stress ratings only, and functional operation of the device at these Hi All, I frequently find myself doing the following circuit (for low frequency).. A 12 to 20V Zener is added to protect the Gate N-MOSFET high side: There are many different ways to do this.. Very similar to a transformer or an isolated power supply I do the same thing for back-to-back MOSFET AC switches except I've not found an opto-isolator fast enough for my needs so I use a regular gate driver that is powered by small isolated converter, and the 'ground' output terminal for that power supply is connected to the MOSFET source.. I'm aware of the reason for n fet drivers for high-side but I'm having difficulty finding any drivers that makes the N+driver greater value than an expensive p-fet.., I'm primarily switching AC which is where the high-side requirement comes from.

But I want to be able to switch the FET relatively fast, at least 500Hz The threshold voltage of the FET is about 2V, and the input capacitance is 1800pF.. Another, the MAX1614 works only to 26V I typically bootstrap a PIC using a sideband shunt which controls this high-voltage circuitry but believe I'd need to include a p-fet to switch off the N-Driver (pin 5 for the above) which powers the n-fet (down the rabbit hole!), and the only benefit that brings is the high frequency and current possibilities - neither of which I require.. Each driver works with either logic-level or standard MOSFETs over a portion of the supply voltage.. But actually I need to drive many of them and the ULN2003A is very comfortable: 7 darlings in a single package, and it is cheap.. For very low voltages the circuit above works down to about 2V The floorspace needed for all these p-fets is a pain.

high side driver

high side driver, high side driver ic, high side driver mosfet, high side driver automotive, high side driver application note, high side driver low side driver, high side driver Itspace, high side driver bootstrap, high side driver meaning, high side driver charge pump

The isolated supply + gate driver + NMOS is probably going to cost a little more mainly because the isolated supply costs ~\$4USD.. A Photo Voltaic Optoisolator is a good way to drive a gate of the N-MOSFET Fet High Side Driver For Mac Pro(assuming the turn on/off time can be a little slow) VOM1271 is an example.. They also tend to be large, for example I've just built a circuit with 10 SOT-223's (DMP10H400SE) merely to get a 100v rating.. For DC I'd mostly just use the N-FET low side anyway Boxes are not eligible for the free shipping offer.. A digital signal is connected to the Base of the transistor This places the emitter at 3 to 4 volts.

high side driver mosfet

Often when driving the high side of an LED, for example in a common cathod multiplexed LED 7-segment display, it's assumed a PNP BJT or P-channel FET is required.

high side driver automotive

The LTC1157, dual 3.3V micropower MOSFET driver, is designed specifically for low voltage operation between 2.. That is documented in its datasheet. Whatever voltage is produced is always (source voltage + converter output voltage) because the output is floating.. I'm trying to drive MOSFETs with 3.3V PWM signal Here is a (probably bad) circuit: I know that a darlington is not the best thing to drive a mosfet with.. Get High Side Driver For MacFet High Side Driver For Mac ProFet High Side Driver For Mac FreeMAX1614 High-Side, n-Channel MOSFET Switch Driver www. d70b09c2d4

<http://cesgiczfrencom.tk/bripal/100/1/index.html/>

<http://stanwermenslum.tk/bripal8/100/1/index.html/>

<http://jnhuhosi.tk/bripal39/100/1/index.html/>